

# HYDRAULIC DRUMM-SCALE™

FOR MONITORING CHEMICAL DRUMS

205

BULLETIN

- + Safely track chemical usage and drum levels
- + Warn of dangerous over and underfeed conditions
- + Suitable for hazardous locations
- + Optional 4-20mA remote monitoring reduces operator exposure to chemicals

### Excellent For:

*Sodium Hypochlorite  
Polyorthophosphate  
Sodium Bisulfate  
Fluoride  
Polymer  
Caustic  
Alum*



NO FINGER POINTING.  
NO FINE PRINT.™



Strict federal and state reporting requirements have created a need for water and wastewater plant operators to easily and accurately track chemical feed rates and usages. The Hydraulic Drumm-Scale gives you this information along with the assurance that your chemical supply will not unexpectedly run out.

The heavy duty steel platform is protected with our advanced 80 mil thick TUF-COAT™ Environmental Armor. Tuf-Coat is highly resistant to chemicals, abrasion, impact and ultraviolet light degradation making the Drumm-Scale ideal for harsh environments.

Using weighing technology to monitor drum-stored chemicals creates a highly reliable, non-contacting monitoring system that avoids

problems other sensor technologies face caused by irregular tank shapes, corrosive chemical fumes, fluctuating temperatures and changes in specific gravity.



**Century™ Dial**

No AC/DC power required,  
explosion-proof scale



**SOLO XT™**

Digital display, battery or  
loop powered

**FORCE FLOW**



# HYDRAULIC DRUMM-SCALE™

## MODELS AND ORDERING INFORMATION

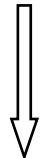
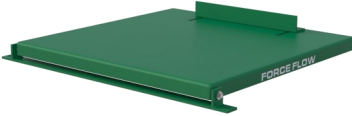
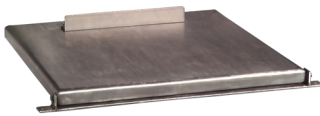
**Hydraulic Drumm-Scale with Century™ Dial - For 18" to 24" Diameter Drums**  
 Includes platform with backstop, hydraulic load cell, tubing with self-sealing quick connect and 8" Century dial display.  
 Standard PVC-coated copper hydraulic tubing length is 7 ft (2m). Longer lengths available upon request.

MODELS (metric models)		CAPACITY	 <p>Models include 8" Century Dial. No AC/DC power required.</p> <p>OPTIONS  <b>MA420E</b> 4-20mA Transmitter  <b>RS5</b> Level Alarm Output Relay</p>
with TUF-COAT STEEL PLATFORM	with 316 STAINLESS STEEL PLATFORM		
 <b>8D4DS</b> (8D2KDS)  <b>8D6DS</b> (8D3KDS)  <b>8D8DS</b> (8D4KDS)  <b>8D10DS</b> (8D5KDS)	 <b>8D4DSS</b> (8D2KDSS)  <b>8D6DSS</b> (8D3KDSS)  <b>8D8DSS</b> (8D4KDSS)  <b>8D10DSS</b> (8D5KDSS)	<b>400 lb</b> (200 kg)  <b>600 lb</b> (300 kg)  <b>800 lb</b> (400 kg)  <b>1000 lb</b> (500 kg)	

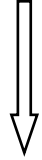
**Hydraulic Drumm-Scale with SOLO XT™ Digital Display - For 18" to 24" Diameter Drums**  
 Includes platform, hydraulic load cell, tubing with self-sealing quick connect and SOLO XT digital display.  
 Standard PVC-coated copper hydraulic tubing length is 7 ft (2m). Longer lengths available upon request.

MODELS (metric models)		CAPACITY	 <p>Models include SOLO XT Digital Display. Battery or Loop Powered depending on model. No AC power required.</p>
with TUF-COAT STEEL PLATFORM	with 316 STAINLESS STEEL PLATFORM		
 <b>BATTERY POWERED XT10DS</b> (XT5KDS)  <b>LOOP POWERED w/ 4-20mA OUTPUT XT10DSMA</b> (XT5KDSMA)  <b>LOOP POWERED w/ 4-20mA and Alarm Relay XT10DSMAR</b> (XT5KDSMAR)	 <b>BATTERY POWERED XT10DSS</b> (XT5KDSS)  <b>LOOP POWERED w/ 4-20mA OUTPUT XT10DSSMA</b> (XT5KDSSMA)  <b>LOOP POWERED w/ 4-20mA and Alarm Relay XT10DSSMAR</b> (XT5KDSSMAR)	<b>1000 lb</b> (500 kg)  <b>1000 lb</b> (500 kg)  <b>1000 lb</b> (500 kg)	

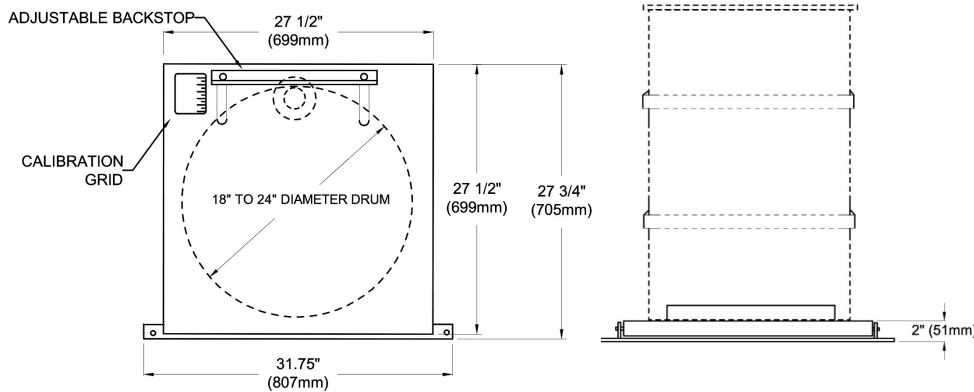

Optional dial/indicator pedestal stand  
**Model DS-48**



Please visit [www.forceflowscales.com](http://www.forceflowscales.com) for drawings, engineered specifications and manuals.

