

HYDRAULIC DRUMM-SCALE™

FOR CHEMICAL INVENTORY MANAGEMENT



- PREVENTS SYSTEMS FROM RUNNING EMPTY
- NON-INTRUSIVE AND NON-CONTACTING
- EXCELLENT FOR DOCUMENTING CHEMICAL USAGE
- LOW PROFILE
- CORROSIVE RESISTANT EPOLY POWDER COATING
- LOW-LEVEL ALARMS AND 4-20MA SIGNALS AVAILABLE
- 5-YEAR WARRANTY PERFORMANCE GUARANTEE (NO FINGER POINTING, NO FINE PRINT)

FLUORIDE
POLYMER
SODIUM HYPOCHLORITE
SODIUM BISULFITE
POTASSIUM PERMANGANATE
SODIUM HYDROXIDE
CAUSTIC
ALUM
ETC.

MONITORS
CHEMICAL
LEVEL

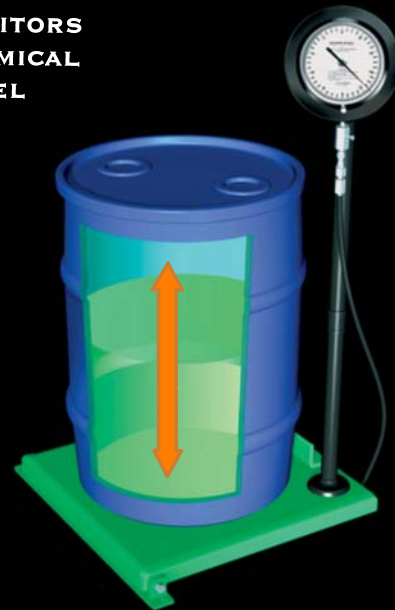

DRUM & CARBOY SCALE FOR MUNICIPAL & INDUSTRIAL CHEMICAL FEED SYSTEMS

STRICT FEDERAL AND STATE REPORTING REQUIREMENTS HAVE CREATED A NEED FOR MUNICIPAL PLANT OPERATORS TO EASILY AND ACCURATELY TRACK CHEMICAL FEED RATES AND USAGES IN WATER AND WASTEWATER TREATMENT PLANTS. ALSO, BY KNOWING EXACTLY HOW MUCH CHEMICAL REMAINS, PLANT OPERATORS CAN BE ASSURED THAT THE DRUM WILL NOT RUN EMPTY DURING THEIR ABSENCE.

OUR LOW PROFILE CORROSION RESISTANT PLATFORM ALLOWS OPERATORS TO LOAD AND UNLOAD DRUM PACKAGED CHEMICALS SAFELY AND EASILY.

CENTURY HYDRAULIC SYSTEM REQUIRES NO POWER, IS VIRTUALLY MAINTENANCE FREE AND IS IMMUNE TO POWER FAILURE, LIGHTNING STRIKES AND RFI/EMI.



USING THE DRUMM-SCALE FOR YOUR INVENTORY MANAGEMENT RESULTS IN AN INEXPENSIVE, NON-CONTACTING, HIGHLY RELIABLE METHOD OF MEASURING LEVEL. WEIGHT (OR MASS) IS AN INHERENTLY ACCURATE MEANS OF MEASURING VESSEL CONTENTS BECAUSE IT IS INDEPENDENT OF VESSEL SHAPE, TEMPERATURE, CORROSIVE CHARACTERISTICS OF THE CONTENTS. THE DRUMM-SCALE IS EASILY INSTALLED BY REGULAR PLANT PERSONNEL AND WITH OUR FULL 5-YEAR WARRANTY, REQUIRES VIRTUALLY NO MAINTENANCE.

FORCE FLOW

2430 Stanwell Drive, Concord, CA 94520 USA
1-800-893-6723 USA/Canada Fax: 925-686-6713
info@forceflow.com . www.forceflow.com

*SEE ALSO WIZARD, SOLO AND XT BULLETINS

HYDRAULIC DRUM-SCALE™

MODELS AND ORDERING INFORMATION

STANDARD MODELS ARE SIZED TO ACCEPT DRUMS OR CARBOYS FROM 18" TO 24" IN DIAMETER (APPROXIMATELY 30 TO 55 GALLON DRUMS). SCALES COME COMPLETE WITH PLATFORM, DIAL STAND, LOAD CELL WITH 5 FEET OF HYDRAULIC TUBING AND 8-1/2" DIAL READOUT. FOR OTHER DIAL SIZES, CAPACITIES AND REMOTE DIAL MOUNTING (UP TO 50 FEET), ALARMS OR TRANSMITTERS, PLEASE CALL FACTORY. FOR TANKS UP TO 1,000 GALLONS, REFER TO CHEM-SCALE BROCHURES.

DESCRIPTION	MODEL NUMBERS			
EPOXY POWDER COATED:	8D4DS	8D6DS	8D8DS	8D10DS
316 STAINLESS STEEL:	8D4DSS	8D6DSS	8D8DSS	8D10DSS
CAPACITY:	0-400 LBS	0-600 LBS	0-800 LBS	0-1000 LBS
DRUM SIZE:	18" - 24"	18" - 24"	18" - 24"	18" - 24"
PLATFORM SIZE:	27 1/2" x 27 1/2"	27 1/2" x 27 1/2"	27 1/2" x 27 1/2"	27 1/2" x 27 1/2"
WEIGHT:	103 LBS	103 LBS	103 LBS	103 LBS
FULL SCALE ACCURACY:	1/2 OF 1%	1/2 OF 1%	1/2 OF 1%	1/2 OF 1%
MINIMUM INCREMENTS:	1 LB	2 LB	2 LB	2 LB

SPECIFYING GUIDELINES: A) SIZE SCALE CAPACITY TO MATCH GROSS WEIGHT (CHEMICAL & TANK TARE WEIGHT). B) TANK DIAMETER SHOULD NOT EXCEED 24". C) SUPPLY CONNECTIONS MUST BE FLEXIBLE & PREFERABLY CONNECTED AT PIVOT END OF PLATFORM.

METRIC MODELS AVAILABLE
AT NO EXTRA CHARGE

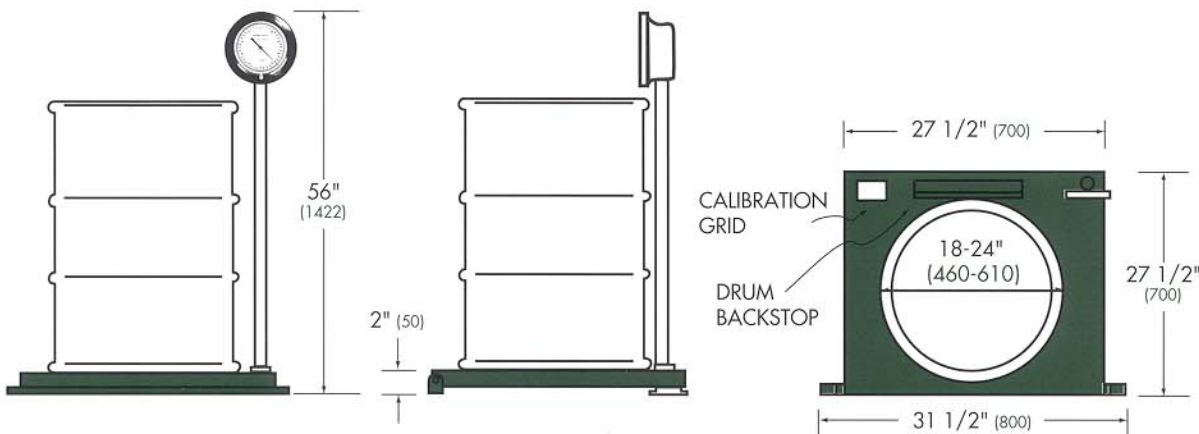

DIMENSIONS: INCHES (MILLIMETERS)

TYPICAL SPECIFICATION FOR HYDRAULIC DRUM SCALES

DRUM SCALE SHALL BE OF THE HYDRAULIC LOAD CELL TYPE. SCALE SHALL BE SIZED TO ACCEPT DRUMS OR CARBOYS FROM 18" TO 24" IN DIAMETER. PLATFORM HEIGHT SHALL BE NO MORE THAN 2" TO ALLOW EASY LOADING AND UNLOADING OF DRUMS. PLATFORM SHALL BE CONSTRUCTED OF _____ (EPOXY POWDER COATED OR 316 STAINLESS) STEEL.

LOAD CELL SHALL BE OF THE TEMPERATURE STABLE, ROLLING DIAPHRAGM TYPE. A 5' FLEXIBLE LENGTH OF PVC COATED COPPER SHALL LEAD FROM THE LOAD CELL TO ALLOW EASY INSTALLATION OF THE DIAL ON THE PLATFORM MOUNTED DIAL STAND. LOAD CELL SYSTEM SHALL REQUIRE NO ELECTRIC POWER AND SHALL BE IMMUNE TO ALL RFI/EMI, POWER FAILURES AND LIGHTNING STRIKES.

DIAL DIAMETER SHALL BE 8 1/2" AND READ 0-____ LBS WITH PROVISION FOR TARE ADJUSTMENT. DIAL SHALL BE TEMPERATURE STABLE WITH DAMPER INSTALLED TO PREVENT SHOCK DAMAGE. DIAL ACCURACY SHALL BE BETTER THAN 1/2 OF 1% OF FULL SCALE.

SCALE SHALL BE DRUMM-SCALE MODEL 8D____AS MANUFACTURED BY FORCE FLOW EQUIPMENT, 1150-D BURNETT AVE., CONCORD, CALIFORNIA 94520 USA.

OPTIONAL FEATURES

- 4-20MA TRANSMITTER (MODEL MA-420)- LOOP POWERED 4-20MA TRANSMITTER (REQUIRES 12-45 VOLTS DC POWER)
- LEVEL ALARM (MODEL RS-5)-ADJUSTABLE HIGH/LOW LEVEL ALARM WITH 10 AMP MANUAL RESET RELAY OR (MODEL PS-10) FIXED SET POINT 10 AMP PRESSURE SWITCH
- CIRCULAR CHART RECORDERS - CHOOSE 1 OR 7 DAY, ELECTRIC OR WIND-UP
- ADDITIONAL HYDRAULIC HOSE AND FITTINGS - INDICATORS CAN BE REMOTE MOUNTED UP TO 50' FROM SCALE LOCATION
- LOCKING TARE ADJUST KNOB - PREVENTS TAMPERING

