

CHLORINE & SULFUR DIOXIDE
CYLINDER SCALES

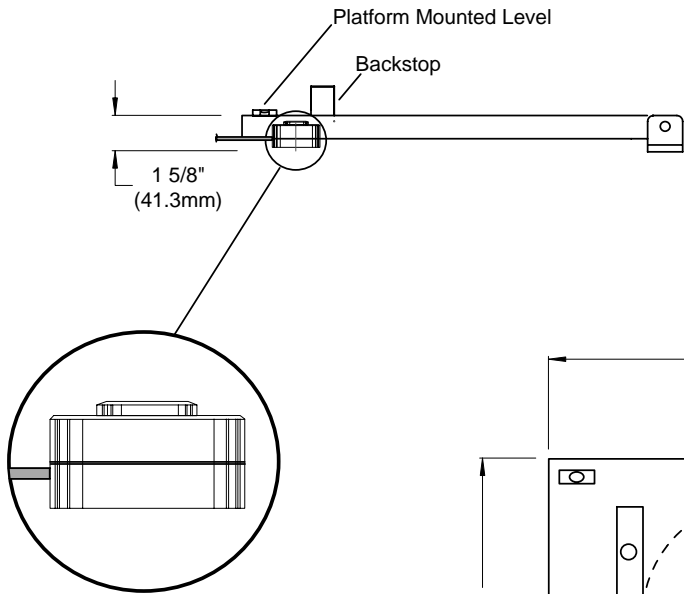

<u>Model No.</u>	<u>Metric Models</u>	
XT150-1	XT68K-1 / XT100K-1	Single Cylinder Scale
XT150-2	XT68K-2 / XT100K-2	Dual Cylinder Scale
XT150-1MA	XT68K-1MA / XT100K-1MA	Sgl scale w/4-20mA Output
XT150-2MA	XT68K-2MA / XT100K-2MA	Dual scale w/4-20mA Output
XT150-1MAR	XT68K-1MAR / XT100-1MAR	Sgl scale w/4-20mA Output & Level Relay
XT150-2MAR	XT68K-2MAR / XT100-2MAR	Dual scale w/4-20mA Output & Level Relay

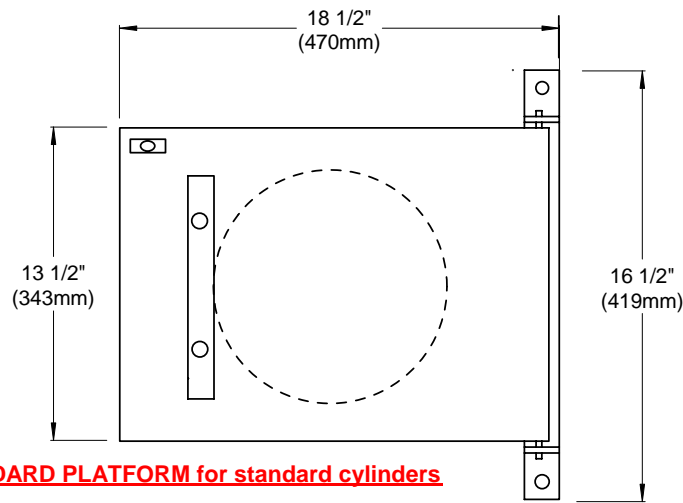

STANDARD PLATFORM for standard cylinders

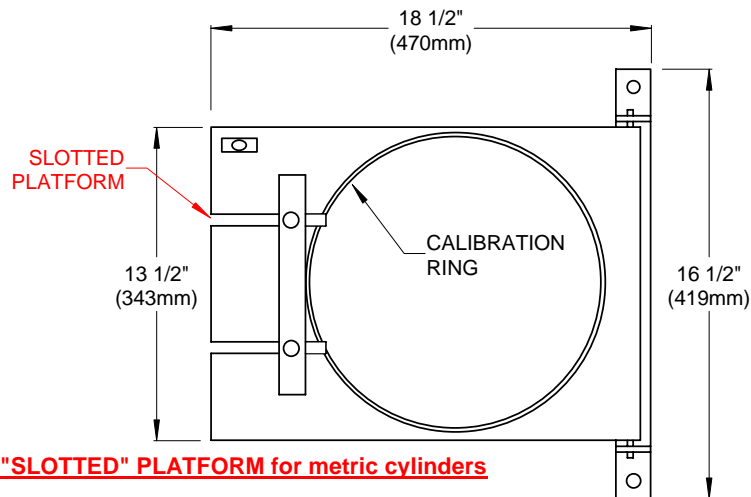

"SLOTTED" PLATFORM for metric cylinders

SOLO XT Cross
Technology Indicator

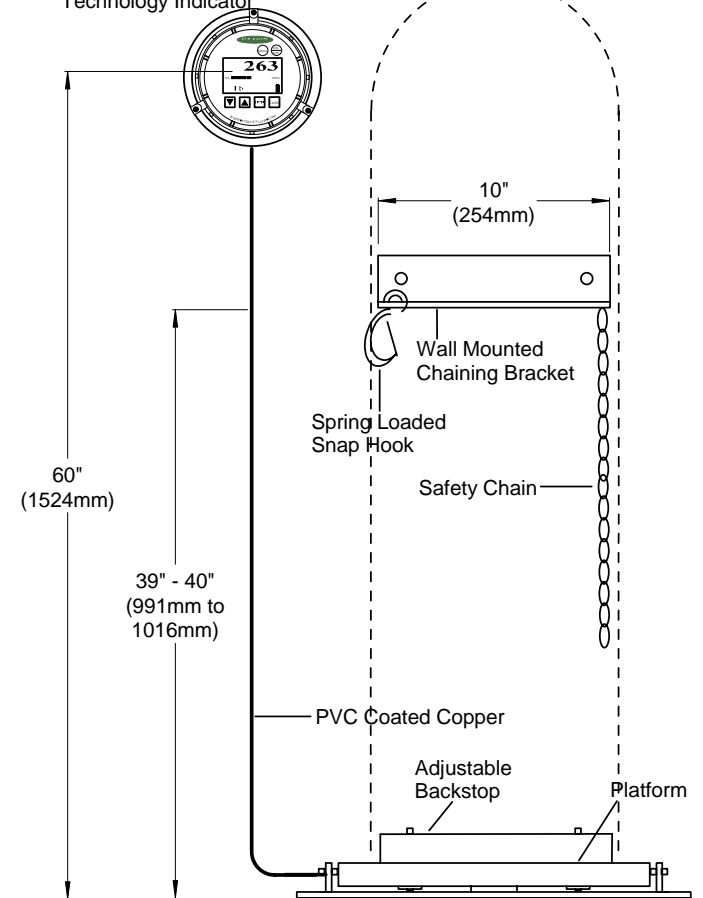

X.1.101-1

FORCE FLOW

1150-D Burnett Ave, Concord, CA 94520 USA
1-800-893-6723 US & Canada, Fax: 925-686-6713
www.forceflow.com / info@forceflow.com

File: T4IO&M\CYL\XT150#XT.tcw (101.pdf)
EMAIL\DRAWINGS\CYL\150#XT.pdf

HYDRAULIC CHLOR-SCALE 150
with SOLO XT Cross Technology
Digital Indicator for Cl₂ & SO₂ Cylinders

Drawn by: SLP/MN
Date: 01/05/94
Revised: 10/17/05
Scale: NONE

Drawing Number
30307
O&M