

WIZARD 4000 Indicator

Wizard Indicator Model No: \_\_\_\_\_

4-20mA Outputs \_\_\_\_\_

Relays \_\_\_\_\_ O = Normally Open, C = Normally Closed  
D = Dry Contact, S = Solid State

Other Options: \_\_\_\_\_

TOP VIEW

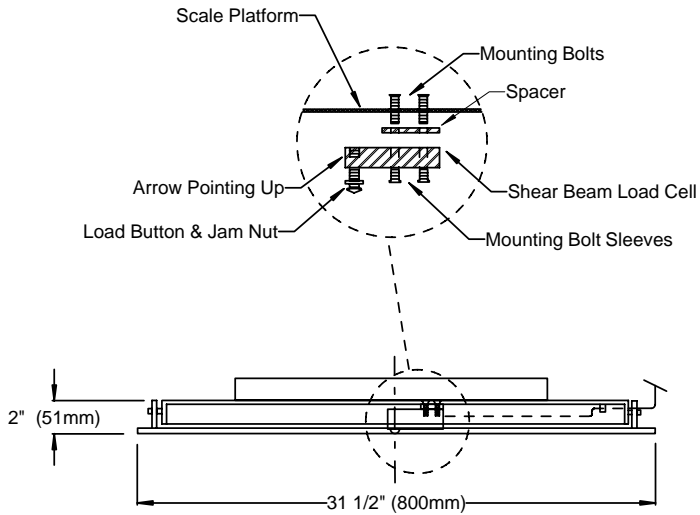
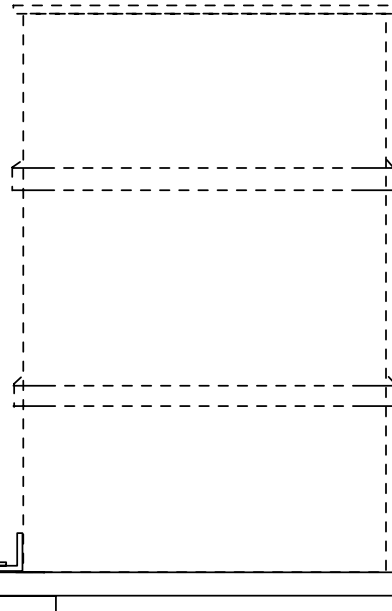

**FORCE FLOW**

2430 Stanwell Dr, Concord, CA 94520 USA  
1-800-893-6723 US & Canada, Fax: 925-686-6713  
www.forceflow.com / info@forceflow.com

File: T4\O&M\DRUM WIZ1\_DRUM WIZ.tcw  
EMAIL\DRAWINGS\DRUM\_DRUM WIZ.pdf

**ELECTRONIC DRUMM-SCALE  
with WIZARD INDICATOR  
for 30- to 55-Gallon Drums  
(Capacities to 1000 lbs or 500 kg)**

Drawn by: SLJ/MT  
Date: 09/01/95  
Revised: 08/22/08 MT  
Scale: NONE

Drawing Number

30290