

MODEL NUMBERS (for Complete Scale)

Model No:	Metric Models:
6D40A (4000 lb)	6D20K (2000 kg)
8D40A (4000 lb)	8D20K (2000 kg)
12D40A (4000 lb)	12D20K (2000 kg)
18D40A (4000 lb)	18D20K (2000 kg)

Complete with Century Dial Indicator

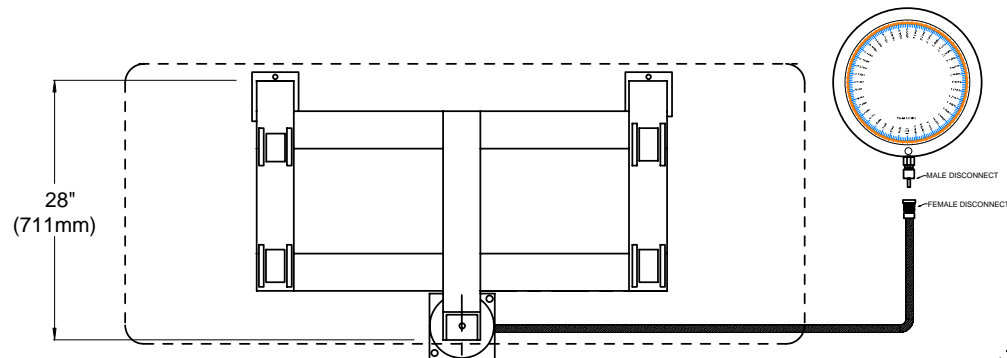

Maintain an even gap on load cell to avoid frequent refillings.

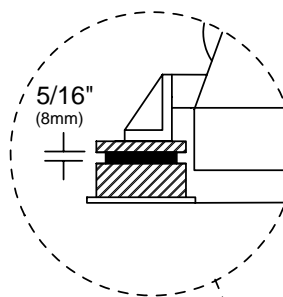

- _____ MODEL NUMBER
- _____ INCH DIAMETER DIAL (LBS or KGS _____)
- _____ FEET OF HYDRAULIC TUBING

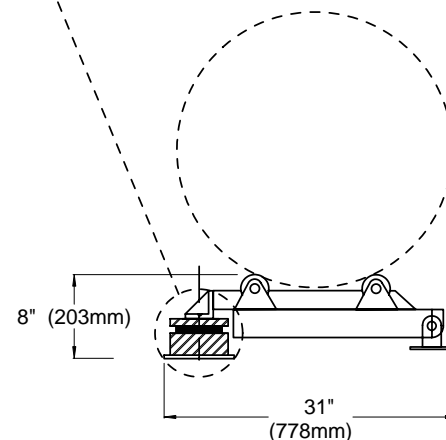
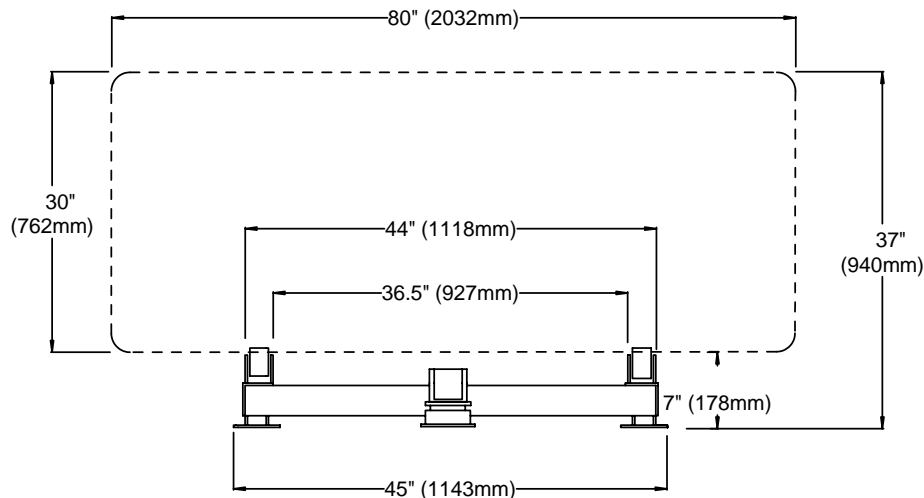

C.1.101



1150-D Burnett Ave, Concord, CA 94520 USA
 1-800-893-6723 US & Canada, Fax: 925-686-6713
 www.forceflow.com / info@forceflow.com

File: T4IO&M\TONHYD_SGL TON HYD.tcw (P04.pdf) (WEB: TON1HYD.pdf)
 EMAIL/DRAWINGS/TON/SGL TON HYD.pdf

**HYDRAULIC SINGLE TANK SCALE
 CHLOR-SCALE with CENTURY DIAL
 (4000 lbs or 2000 kg. Capacity)**

Drawn by: SLP
 Date: 01/15/89
 Revised: 03/01/95
 Scale: NONE

Drawing Number
29634