

**MODEL NUMBERS (for Complete Scale)**

Model No:	Metric Models:
6D80 (8000 lb)	6D40K (4000 kg)
8D80 (8000 lb)	8D40K (4000 kg)
12D80 (8000 lb)	12D40K (4000 kg)
18D80 (8000 lb)	18D40K (4000 kg)

Complete with Century Dial Indicator

\_\_\_\_\_ MODEL NUMBER  
 \_\_\_\_\_ INCH DIAMETER DIAL (LBS or KGS \_\_\_\_\_)  
 \_\_\_\_\_ FEET OF HYDRAULIC TUBING

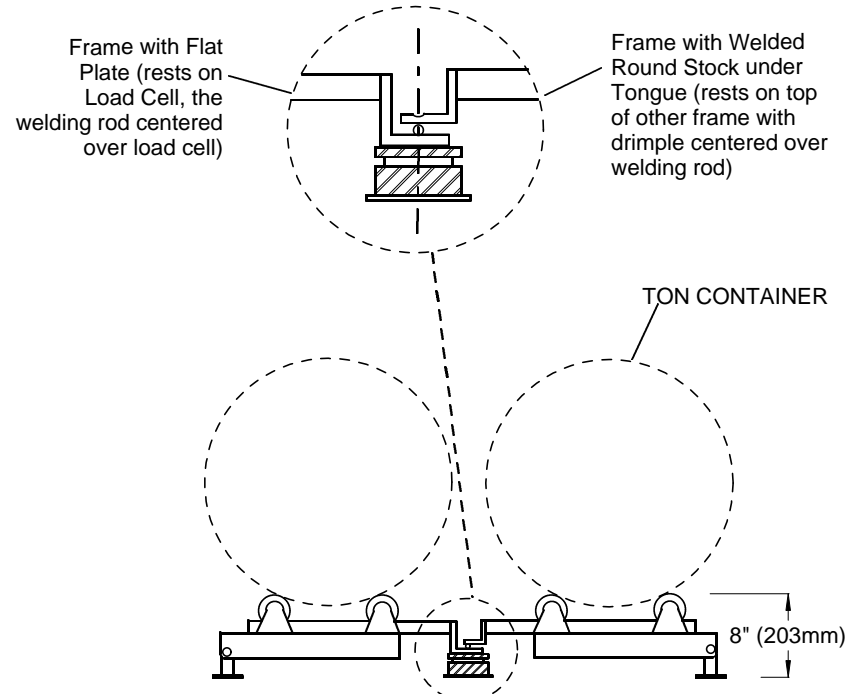

C.1.121



1150-D Burnett Ave, Concord, CA 94520 USA  
 1-800-893-6723 US & Canada, Fax: 925-686-6713  
 www.forceflow.com / info@forceflow.com

File: T4\O&M\TONHYD\DBLO&MIN.tcw (P08.pdf) (WEB: TON2HYD.pdf)

**HYDRAULIC DUAL TANK SCALE  
 CHLOR-SCALE with CENTURY DIAL  
 (8000 Lb. or 4000 Kg. Capacity)**

Drawn by: SLP  
 Date: 01/15/89  
 Revised: 10/16/93  
 Scale: NONE

Drawing Number  
**29633**