

WEIGHT: 720 lbs. (327 kgs)
(palletized for shipment)

NOTE: Use 1/2" x 1-1/2" (13mm x 38mm) Anchor Bolts
See ANCHOR BOLT LOCATION DRAWING

_____ Model Number of Complete Scale
 _____ Feet of Tubing (20/6M std)
 _____ Inch Diameter Century Dial (Lbs. or Kgs. _____)

RECOMMENDATION: 12" (305mm) minimum
pad be used for each foot.

DO NOT PREPOUR ANCHOR BOLTS
Use frame as template.

CONSULT ENGINEERING for flooring
requirements.

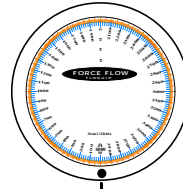
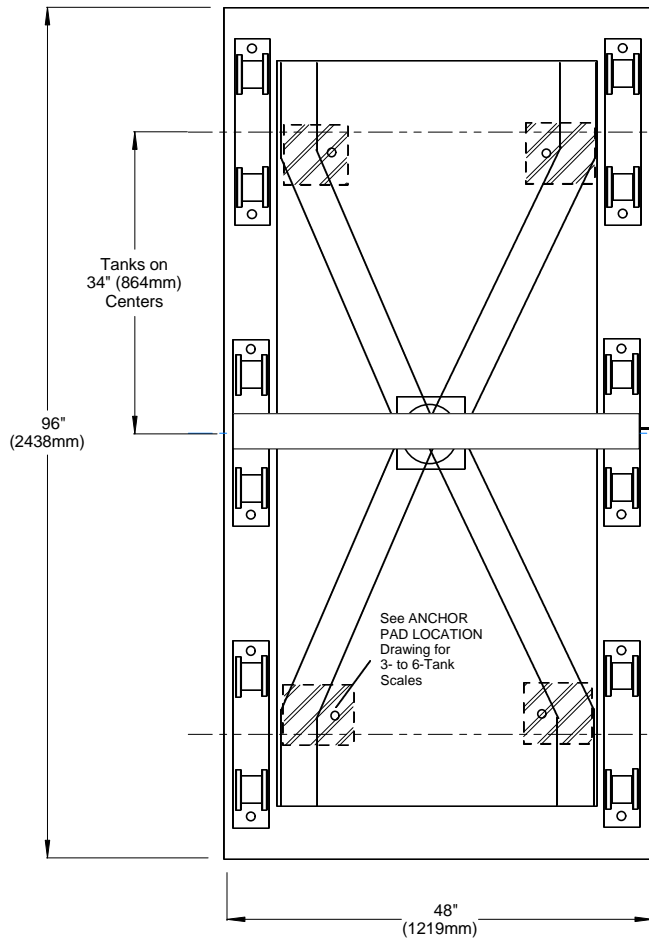

MODEL NUMBERS (for Complete Scale)

12D120 (12,000 lbs)
12D60K (6,000 kgs)

Complete with 12" Century Dial Indicator

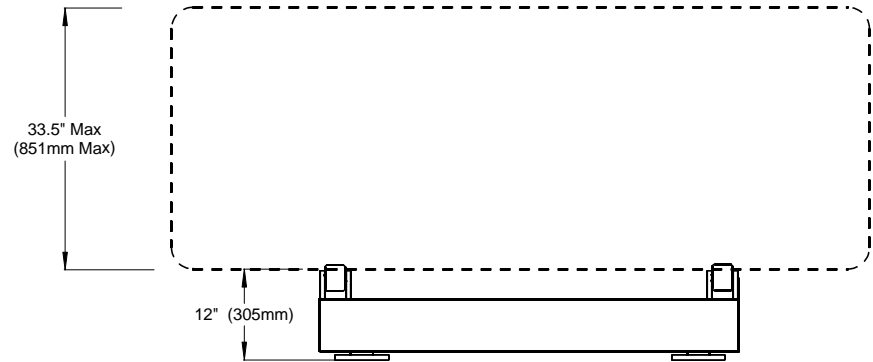

C.1.131



1150-D Burnett Ave, Concord, CA 94520 USA
1-800-893-6723 US & Canada, Fax: 925-686-6713
www.forceflow.com / info@forceflow.com

HYDRAULIC 3-TANK SCALE
CHLOR-SCALE with CENTURY INDICATOR
(12,000 lb. or 6,000 kg. Capacity)

Drawn by: SLP
Date: 09/01/95
Revised: 10/01/00
Scale: NONE

Drawing Number
29528