

NOTE: Use 1/2" x 1-1/2" (13 x 38mm) Anchor Bolts

RECOMMENDATION: 12" (305mm) minimum pad be used for each foot. DO NOT PREPOUR ANCHOR BOLTS. Use frame as template.

MODEL NUMBERS (for Complete Scale)

12D160 (16,000 lbs)
12D80K (8,000 kgs)

Complete with 12" Century Dial Indicator

- _____ Model Number
- _____ Feet of Tubing (20/6M Std)
- _____ Inch Diameter Century Dial (Lbs. or Kgs. _____)

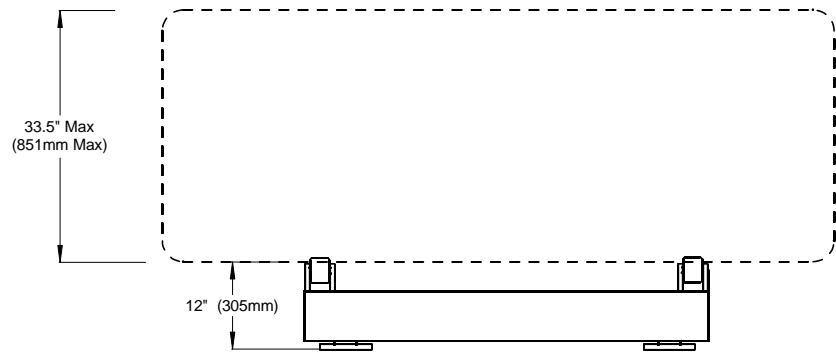
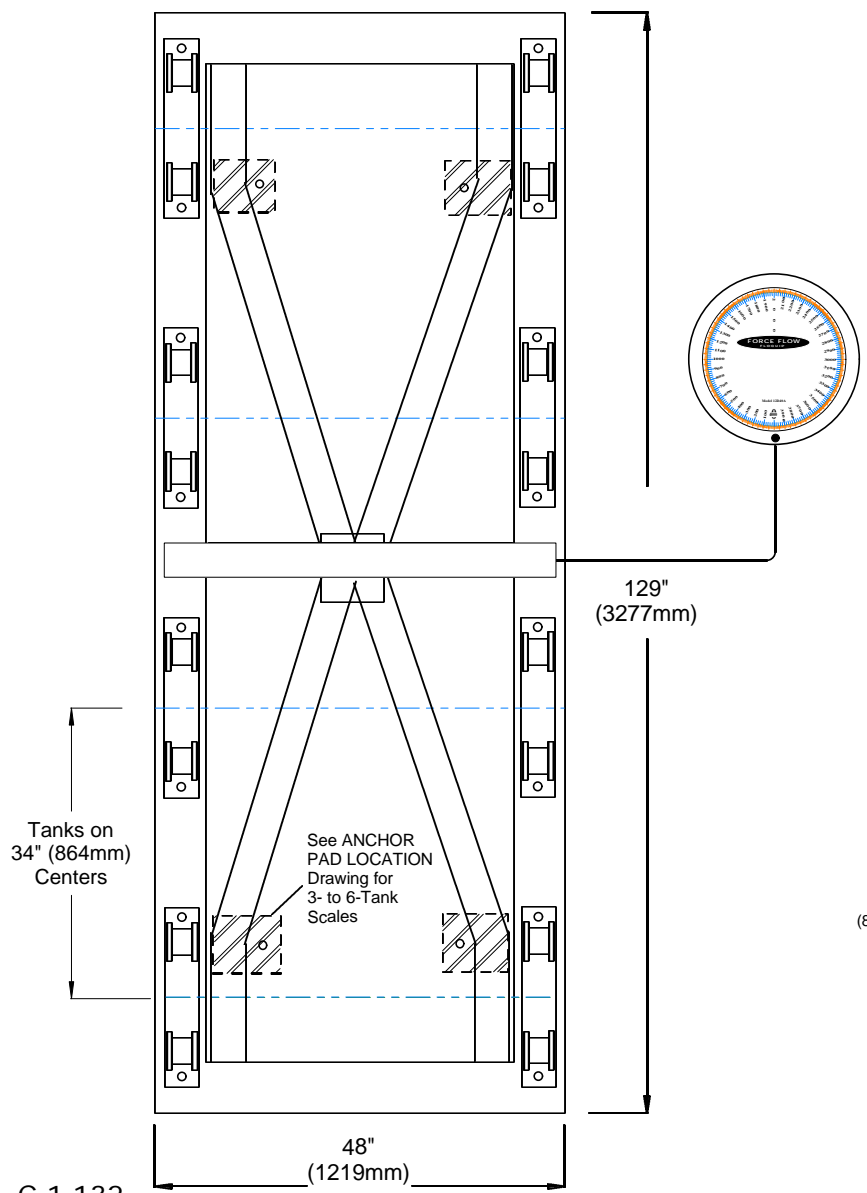

WEIGHT: 1,050 lbs/476 kgs
(palletized for shipment)



1150-D Burnett Ave, Concord, CA 94520 USA
1-800-893-6723 US & Canada, Fax: 925-686-6713
www.forceflow.com / info@forceflow.com

File: T4\O&M\TONHYD\HYD4TANK.tcw (P13.pdf) (WEB: TON4HYD.pdf)

HYDRAULIC 4-TANK SCALE
CHLOR-SCALE with CENTURY INDICATOR
(16,000 lb. or 8,000 kg. Capacity)

Drawn by: SLP
Date: 09/13/00
Revised: 10/01/00
Scale: NONE

Drawing Number
29460