

NOTE: Use 5/8" x 1-1/2" (16mm x 38mm) Anchor Bolts
See ANCHOR BOLT LOCATION DRAWING

RECOMMENDATION: 12" (305mm) minimum pad be used for each foot.

DO NOT PREPOUR ANCHOR BOLTS
Use frame as template.

CONSULT ENGINEERING for flooring requirements.

MODEL NUMBERS (for Complete Scale)

 12D240 (24,000 lbs)
 12D120K (12,000 kgs)

 Complete with 12" Century Dial Indicator

_____ Model Number
 _____ Feet of Tubing (20'/6M Std)
 _____ Inch Diameter Century Dial (Lbs or Kgs _____)

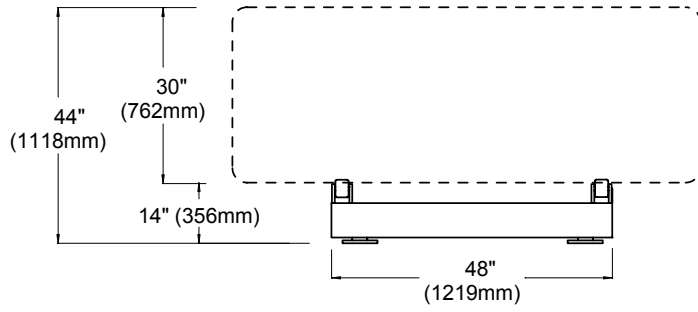

C.1.134

WEIGHT: 2160 Lbs (980 kgs)
(palletized for shipping)



1150-D Burnett Ave, Concord, CA 94520 USA
 1-800-893-6723 US & Canada, Fax: 925-686-6713
 www.forceflow.com / info@forceflow.com

HYDRAULIC 6-TANK SCALE
CHLOR-SCALE with CENTURY INDICATOR
 (24,000 lb. or 12,000 kg. Capacity)

Drawn by: SLP
 Date: 09/01/95
 Revised: 10/23/03
 Scale: NONE

Drawing Number
29462