

MODEL NUMBERS (for Complete Scale)	
Model No:	Metric Models:
6D40A (4000 lb)	6D20K (2000 kg)
8D40A (4000 lb)	8D20K (2000 kg)
12D40A (4000 lb)	12D20K (2000 kg)
18D40A (4000 lb)	18D20K (2000 kg)
Complete with Century Dial Indicator	

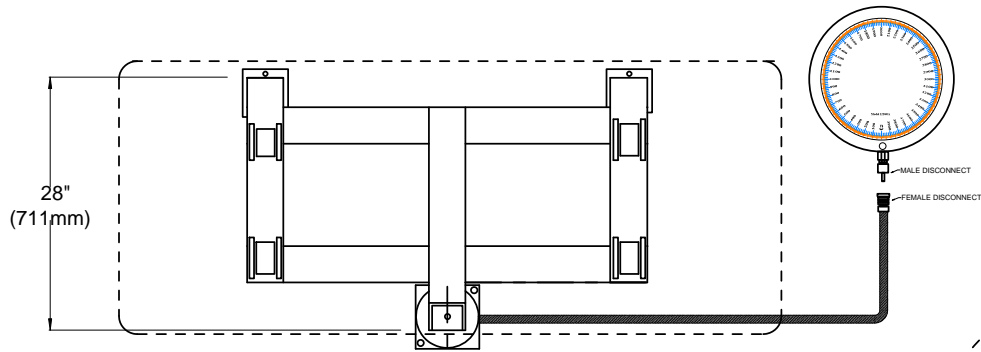

Maintain an even gap on load cell to avoid frequent refillings.

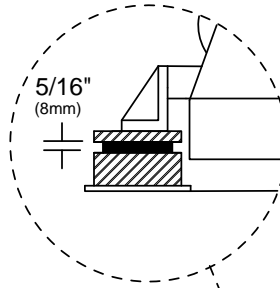

- JOB REFERENCE _____
- DATE _____
- MODEL NUMBER _____
- QUANTITY _____
- DIAL SIZE _____
- TUBING LENGTH _____
- ACCESSORIES _____
- ACCESSORIES _____
- ACCESSORIES _____

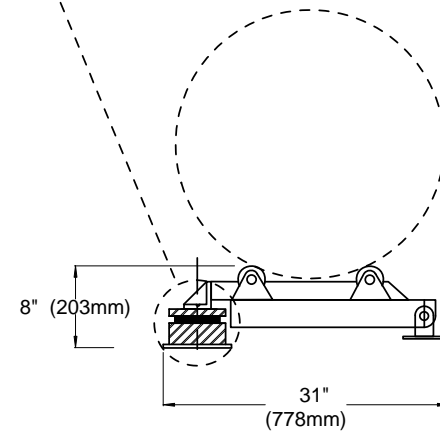
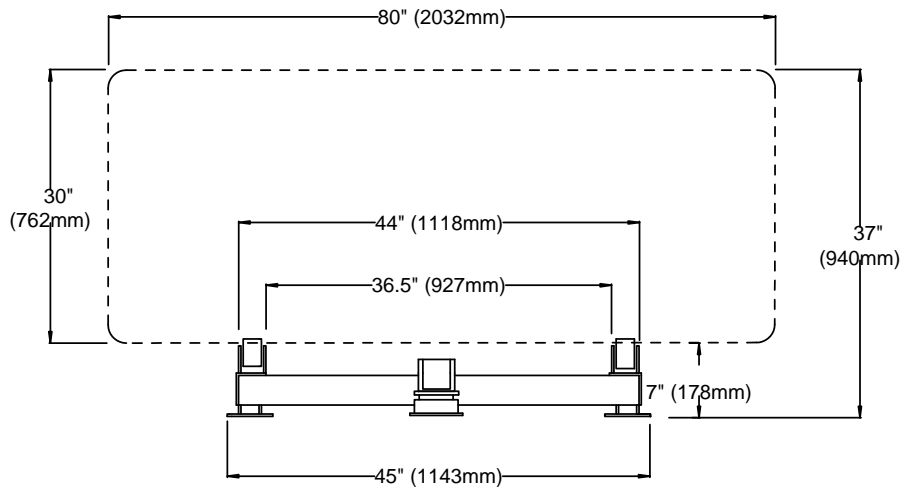

C.1.101



2430 Stanwell Drive, Concord, CA 94520 USA
 1-800-893-6723 US & Canada, Fax: 925-686-6713
 www.forceflow.com / info@forceflow.com

File: T4IO&M\TONHYD_SGL TON HYD.tcw (P04.pdf) (WEB: TON1HYD.pdf)
 EMAIL/DRAWINGS/TON/SGL TON HYD.pdf

**HYDRAULIC SINGLE TANK SCALE
 CHLOR-SCALE with CENTURY DIAL
 (4000 lbs or 2000 kg. Capacity)**

Drawn by: SLP
 Date: 01/15/89
 Revised: 03/01/95
 Scale: NONE

Drawing Number
29634