

WEIGHT: 730 lbs/331 kgs
(palletized for shipment)

NOTE: Use 1/2" x 1-1/2" (13 x 38mm) Anchor Bolts

RECOMMENDATION: 12" (305mm) minimum pad be used for each foot. DO NOT PREPOUR ANCHOR BOLTS. Use frame as template.

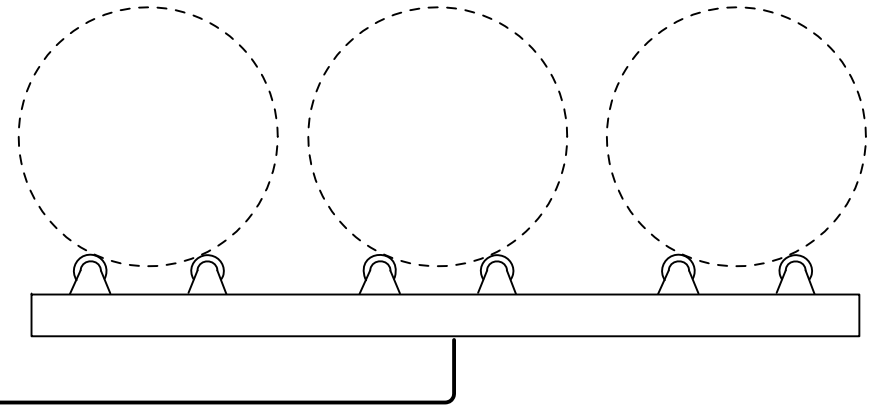
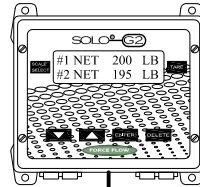
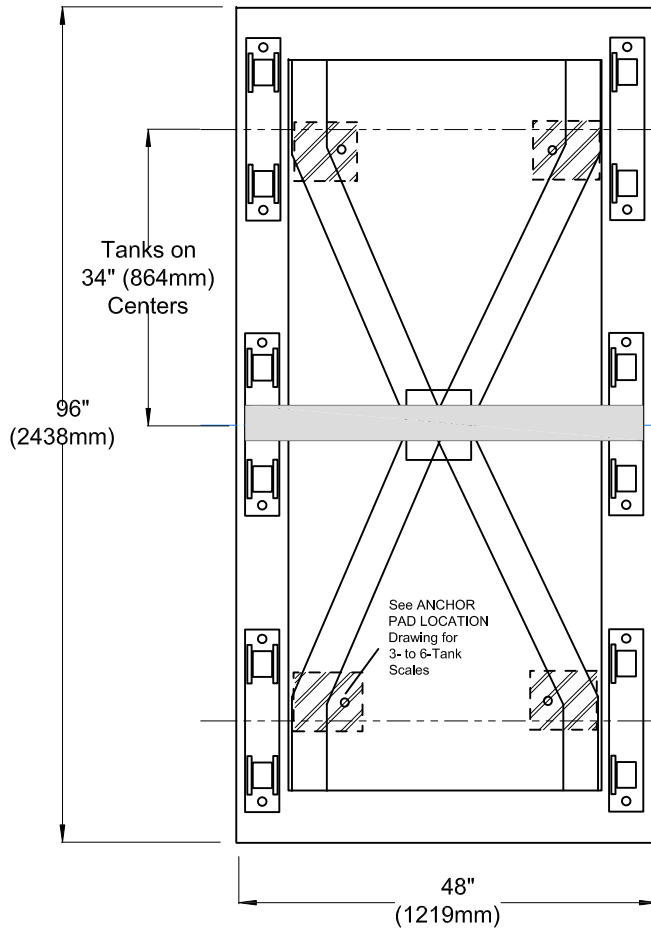

_____ Model Number of Indicator (Lbs. or Kgs. _____)

_____ Model Number of Frames

_____ Feet of Cable (20'/6M Std)

MODEL NUMBERS (for Frame & Load Cell)	
DR120	(12,000 lbs)
DR60K	(6,000 kgs)
MODEL NUMBER (for SOLO G2 Indicator)	
SRG2-1	1-Channel
SRG2-2	2-Channel

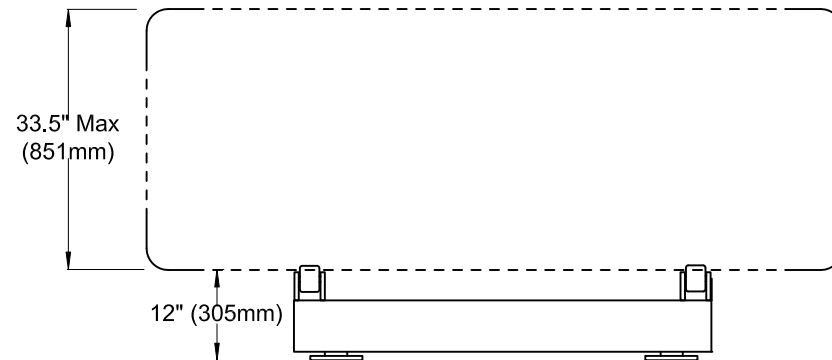

2430 Stanwell Dr, Concord, Ca 94520 USA
1-800-893-6723 US & Canada, Fax: 925-686-6713
WWW.forceflow.com / Info@forceflow.com

ELECTRONIC 3-TANK SCALE
CHLOR-SCALE
with SOLO G2 INDICATOR
(12,000 lb. or 6,000 kg. Capacity)

Drawn by: KBV

Date: 3/03/09

Verified:

Scale:

Drawing Number

31447